



BAYCAR 36" DIAMETER AN-FO TANK



(Units on pressure test)



(View of loading funnel)

Baycar's 36" Ø AN-FO (Ammonium nitrate-fuel oil mixture) tank is available in various capacity ranges from 300Lbs to 2000 Lbs. of mixture. Capacities are based on achievable filling volumes. Now available up to 100 psig design pressure, with a typical operating range of 30 to 60psi. Our AN-FO tanks are constructed of non-magnetic, corrosion resistant stainless steel. Grades available are 304, 316 and 316L, depending on your environmental conditions.

Developed in conjunction with numerous clients from the mining community, the vessels are adaptable to most pneumatic loading operations. Our flexible designs allow numerous options. Each vessel is designed, registered, manufactured, tested and certified to the latest edition of the "A.S.M.E. Code, Section VIII". Vessels also meet the requirements of the O.H.S.A. and regulations for Mines and Mining Plants, PART VI "EXPLOSIVES".

We also repair, register and certify existing pressure vessels.

Our experienced Sales personnel are always ready to provide technical support and assist you in selecting the best configuration of standard and optional equipment to meet your needs. Our Engineering department can also work closely with clients, pneumatic loading equipment suppliers and carrier fabricators to develop custom AN-FO loaders.

Standard

- Up to 100psig Design Pressure
- Internal access for cleaning and maintenance
- Lifting Lugs
- Pneumatic self-closing loading assembly
- Mounting brackets
- Integral purge tube to prevent exhaust blockage
- 30° Bottom cone

Optional

- Discharge configurations
 - 90° 3 x 2 reducer Swivel elbow
 - 1 ½" NPT coupling
 - 2" NPT pipe nipple
- Loading Funnel, Lids and screens
- Vibrator pads
- Support stand
- Manual Closure
- Up to a 12" offset for the bottom cone

Baycar Certificates

TSSA certificate of authorization for the manufacture of pressure vessels

- Fabrication and assembly of power piping in accordance with CSA-B51 and ASME B31.1.
- Fabrication and assembly of process piping in accordance with CSA-B51 and ASME B31.3.
- Repair and alteration of boilers, pressure vessels, piping and fittings in accordance with CSA B51.

A.S.M.E. certificate of authorization for the manufacture of pressure vessels & the use of the "U" code symbol

The National Board of Boiler & Pressure Vessel Inspectors certificate of authorization

Registered to I.S.O. 9001-2000



"After sales support" is a Baycar Standard

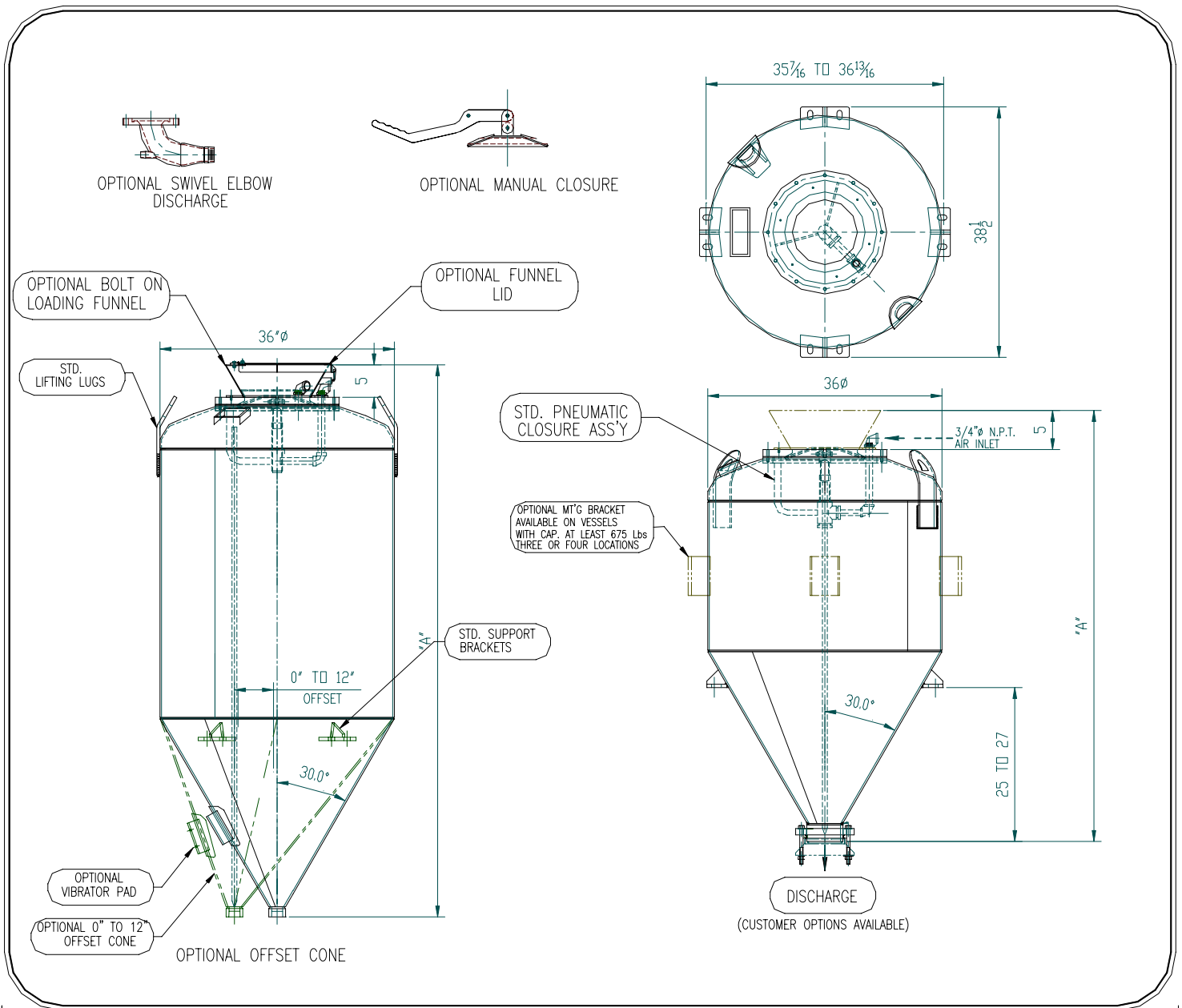

SAMPLE TABLE SHOWING SOME EXAMPLES FOR VOLUMES AND HEIGHTS
**

DIA (INCHES)	CAP (LBS)	VOLUME (ft ³)	* ("A") OVERALL HEIGHT
36"	300 #	5.66	42 1/4
36"	500 #	9.43	48 7/8
36"	630 #	11.88	53 3/8
36"	1060 #	20.00	67 9/16
36"	2000 #	37.74	98 5/8

Height increases by 0.0332"/Lbs of capacity

- * Heights are based on standard straight cone
 - ** CAPACITIES ARE AVAILABLE FROM 300Lbs TO 2000 Lbs.
- "Ask about our custom designed AN-FO tanks, optional equipment and reconditioning"
 Baycar Steel Fabricating Limited, 2032 Old Burwash Road, Sudbury, Ontario, P3E-4Z4
 Ph. (705) 522-0810 – Fax (705) 522-8019

E-mail: info@baycar.com

Please do visit our web site at: " www.baycar.com "